

SPOOL VALVE

DAQ204

Installation, Maintenance and
Operating Instructions

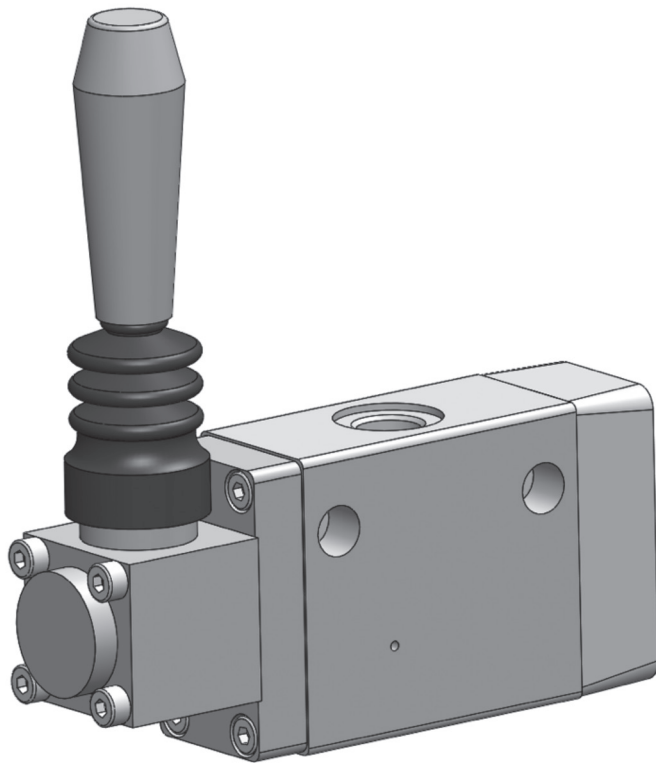

TABLE OF CONTENTS

1. INTRODUCTION.....	3
1.1 Definitions.....	3
2. LABEL DESCRIPTION.....	3
3. INSTALLATION PROCEDURE	3
4. TECHNICAL SPECIFICATION.....	4
5. MAINTENANCE	4
6. DISASSEMBLY	4
6.1 Disassembly of DAQ204.....	4
6.2 Exploded view	5
7. ASSEMBLY	6
7.1 Part list.....	7
8. PACKAGING & STORE	7
9. ASSISTANCE	7

READ THESE INSTRUCTIONS FIRST!

These instructions provide information about safe handling and operation of the valve.
If you require additional assistance, please contact the manufacturer or manufacturer's representative.
Addresses and phone numbers are printed on the back cover.
See also www.metso.com/valves for the latest documentation.

SAVE THESE INSTRUCTIONS!

1. INTRODUCTION

Thank you for choosing METSO product. Each product is fully inspected after the production to offer you the highest quality. In order to fully utilize the product, we strongly recommend users to read this manual carefully and understood.

This manual provides information on installation; operation and maintenance procedures and related instructions for the RMEBS make DAQ204 SPOOL VALVE.

The aim of this literature is to support the use of products in correct manner, and all the technical information provided in the catalogue.

The manual should be given to the end user.

The manual can be changed or revised without any prior notice. Any changes in product's specification, structure, and/or any components may not result immediate revised version of the manual.

The manual should not be duplicated or reproduced for any purpose without any consent of RMEBS Manufacturers & Engineers Private Limited, INDIA.

Manufacturer Warranty

For the safety, it is vital to follow instructions in the manual. It is not RMEBS's liability for any damages which caused by users' negligence.

It is not RMEBS's liability for any damages or accidents which resulted by any alteration or modification of the product and parts. If alteration or modification is necessary, please contact the RMEBS directly.

RMEBS warrants the product from the date of original retail purchase of the product for one (1) year, except as otherwise stated.

RMEBS warranty will not cover the products that the product have been subjected to abuse, accident, alteration, modification, tampering, negligence, misuse, faulty installation, lack of reasonable care, repair or service in any way that is not contemplated in the documentation for the product, or if the model or serial number has been altered, tampered with, defaced or removed; damages that occurs in shipment, failure due to power surge, and cosmetic damage. Improper or incorrectly performed maintenance or report voids this Limited Warranty.

For detailed warranty information, please contact : RMEBS MANUFACTURERS & ENGINEERS PRIVATE LIMITED, Manapada road, Dombivli (e), Maharashtra, India, Pin - 421204

1.1 Definitions

WARNING:

IF NOT OBSERVED, USER INCURS A HIGH RISK OF SEVERE DAMAGE TO PRODUCT AND/OR FATAL INJURY TO PERSONNEL.

CAUTION: If not observed, user may incur damage to product and/or injury to personnel.

NOTE: Advisory and information comments provided to assist maintenance personnel to carry out maintenance procedures.

2. LABEL DESCRIPTION

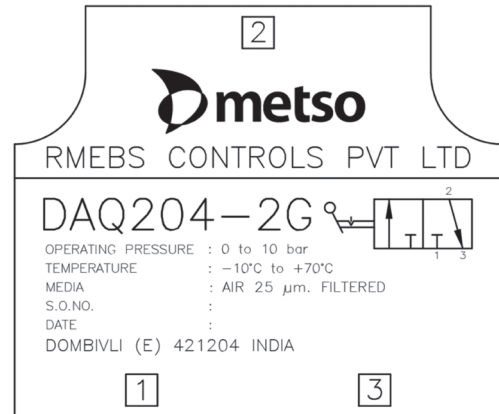

Label of the DAQ204-2G defines the precise feature. This description is written below the RMEBS logo and is as follow.

Model no:	DAQ	SPOOL VALVE 3/2 valve.
	2	1/4", 3- 3/8" , 4 - 1/2" .
	04	2 Position, Hand operated.

External air pressure 3 to 10 bar.

Temperature -10° C to +70°C

S.O. NO. Sales order number.

DATE Date of manufacturing.

Dombivli – 421204 INDIA Brief address.

3. INSTALLATION PROCEDURE

CAUTION: Blow out air lines and fittings before installation. Use dry and oil free air. Do not dismantle the DAQ204 while operation is in line. Do not allow dirty air or fluids to get into the DAQ204. Use filter unit (filter size 40µm, 3°C) for dust and moisture removal.

NOTE: Ensure the installation meets the legal and regulatory requirements of the country and state of use. The DAQ204 assembly should be left in the original packing until it is required for the use.

1. Hemp filaments, jute or even Teflon ribbons are normally not required, As the part connections are accurately threaded. By chance, if any of these or any

other tightening medium get into the operational area inside the DAQ204, possible damage of the DAQ204 could not be ruled out.

- Clean all pipes and tube fittings thoroughly with suitable means. As even when brand new pipes are fitted, unclean interior are quite covered with dirt and dust.
- Avoid impact on the DAQ204. These may happen during transportation/ erection/ mishandling.

4. TECHNICAL SPECIFICATION

Model	DAQ204
Operation type	Internal Pilot operated
Type	3/2 single solenoid
Port	1/4" BSP / 1/4" NPT
Operating Pressure	2.5 to 10 kg/cm ²

5. MAINTENANCE

NOTE: The DAQ204 must be removed from installation prior to maintenance. All the connections/ports have to be disconnected prior to disassembly. All the mountings, accessories and spare parts used or replaced must be original from RMEBS.

RMEBS recommends "RMEBS M 55" grease for greasing. Apply the grease with soft brush or similar. In case of any difficulty consult RMEBS distributor.

- Install, operate and maintain as per the instructions and recommendations of this manual.
- Any deviation from the above will cease the responsibilities of RMEBS.

6. DISASSEMBLY

WARNING:

ALL ELECTRIC AND PNEUMATIC CONNECTIONS SHOULD BE REMOVED BEFORE STARTING DISASSEMBLY.

CAUTION: Do not place dismantled part on any diary/work bench but keep it on clean paper/cloth in same sequence as you have dismantled it.

NOTE: It is advisable to replace all the rubber parts using genuine RMEBS spare kit. Numbers in parentheses, () indicate the bubble number (reference number) used on the RMEBS Assembly details and Part List.

6.1 Disassembly of DAQ204

- Lift the bellow (8) up and remove the pin (9) from bracket.

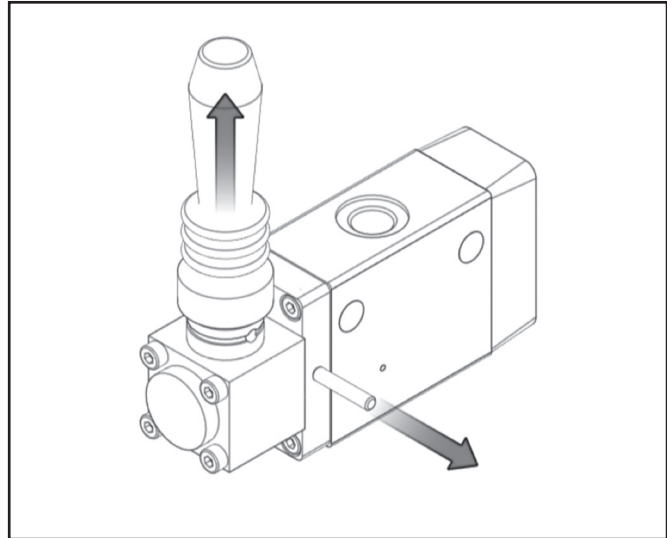

- Remove the guide boss with knob (7) from bracket (6).

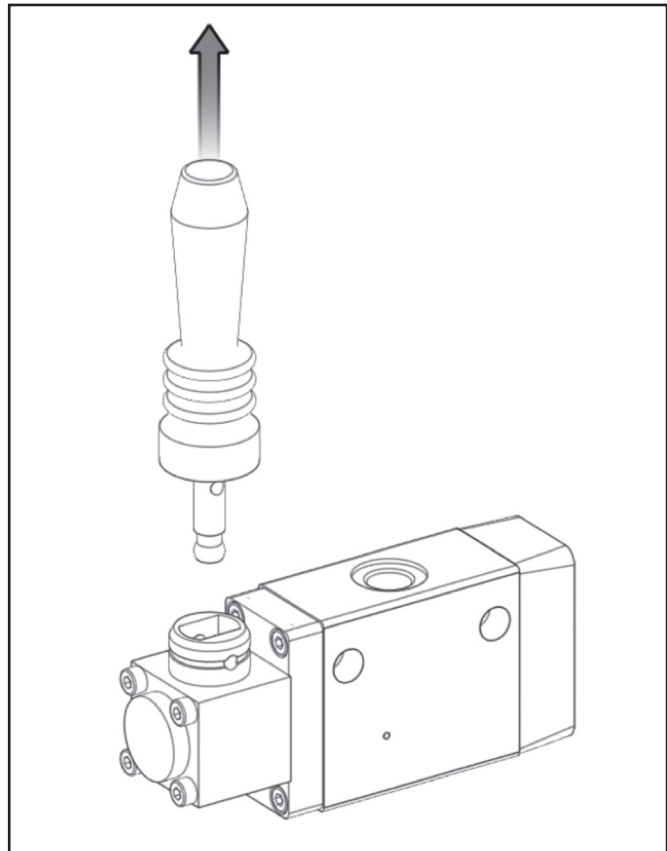

- Remove 4 bolts (17) from bracket (6) and thereby remove the bracket (6) from body.

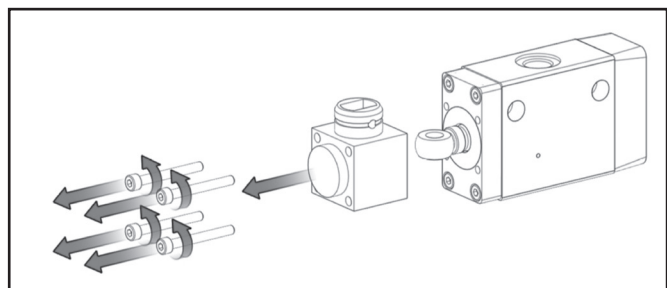

4. Remove 4 bolts (15) from cover (5) and remove the subassembly of cover (5), bush (10), ball holder (11), eye bolt (16), and spool kit (2) from the body.

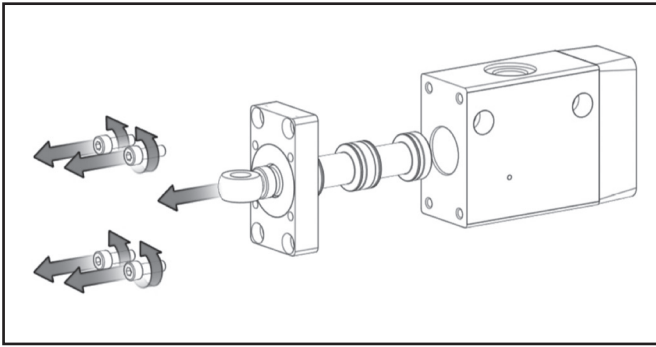

6. Separate out ball holder (11) from the cover (5) and then remove the spring (4) and ball (19) from ball holder (11).

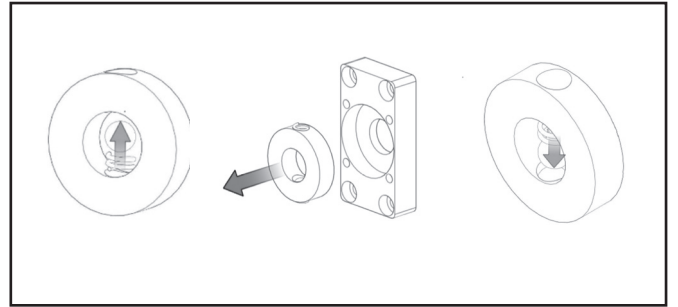

5. Separate out eye bolt (16), bush (10), spool kit (2), and O-ring (14) from the cover.

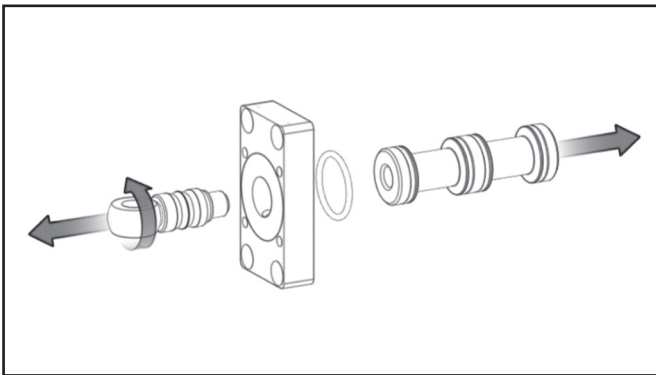

7. Remove the 4 bolts (15) from the spring cover (3), thereby remove the spring cover (3) from the body (1).

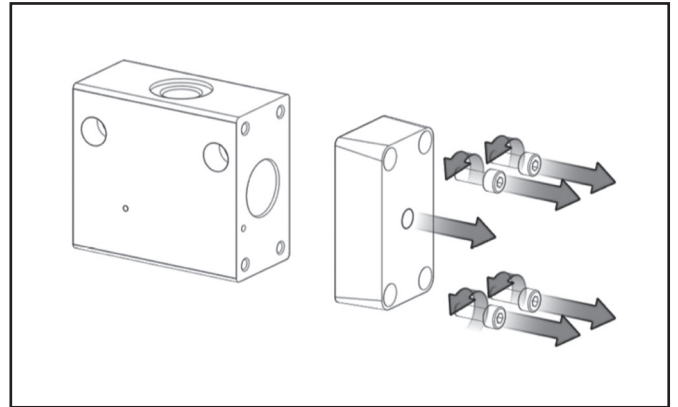

6.2 Exploded view

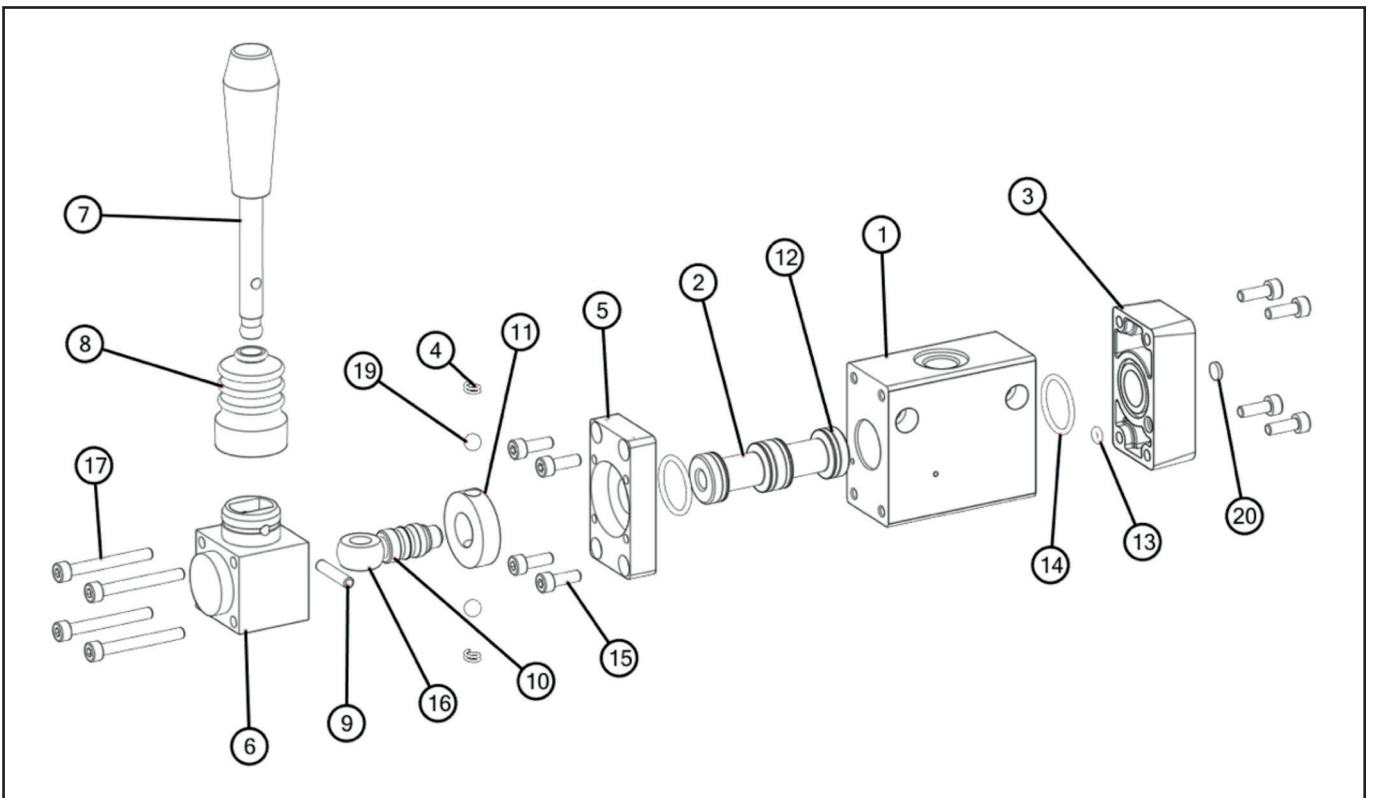

7. ASSEMBLY

NOTE: Follow the sequence as given below to ensure proper assembly.

1. Clean all parts with soap water and dry.
2. Apply a layer of RMEBS recommended grease to the inner face of the body (1). (grease: RMEBS m 55).
3. Insert seal (15) on the spool (3)
4. While inserting spool into the body applies a thin layer of grease on the seal.
5. Insert spring cover (3) into the body (1) and screw it using 4 bolts (19).

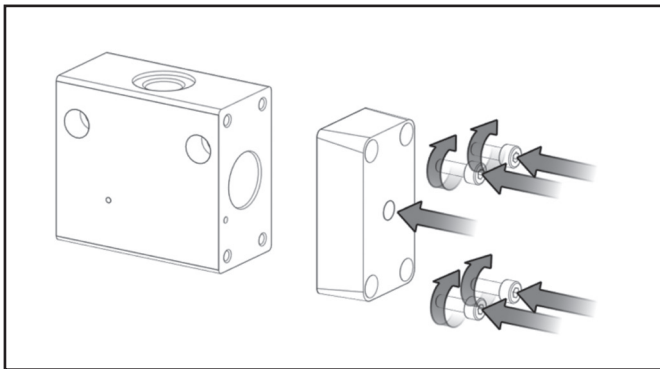

6. Separately make the assembly of ball holder, cover, spring and ball. Then use this assembly for making a subassembly of spool kit, cover, ball holder, eye bolt, O-ring and bush.

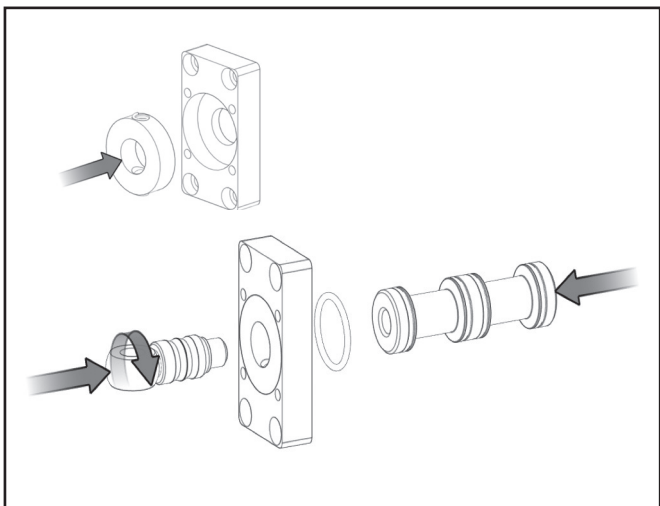

7. Now insert the above subassembly into the body and screw it with the 4 bolts.

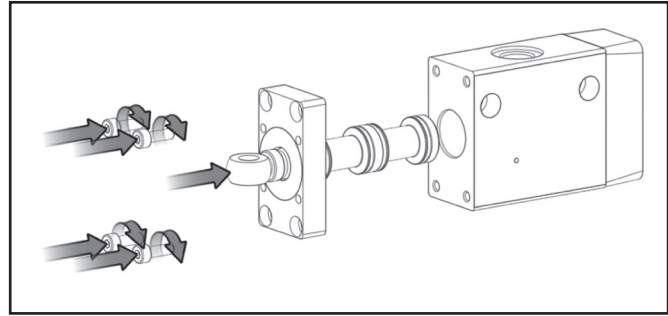

8. Place bracket on the body and screw it with the 4 bolts.

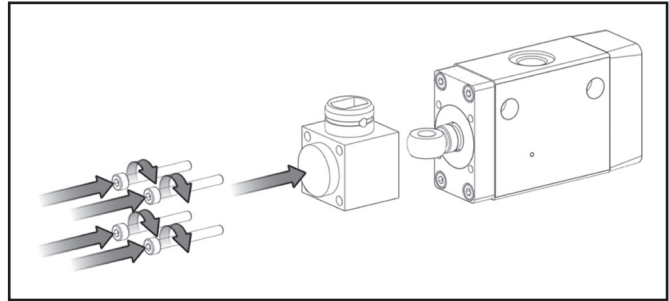

9. Insert guide boss with knob into the bracket and fit the end of the knob into the eye bolt.

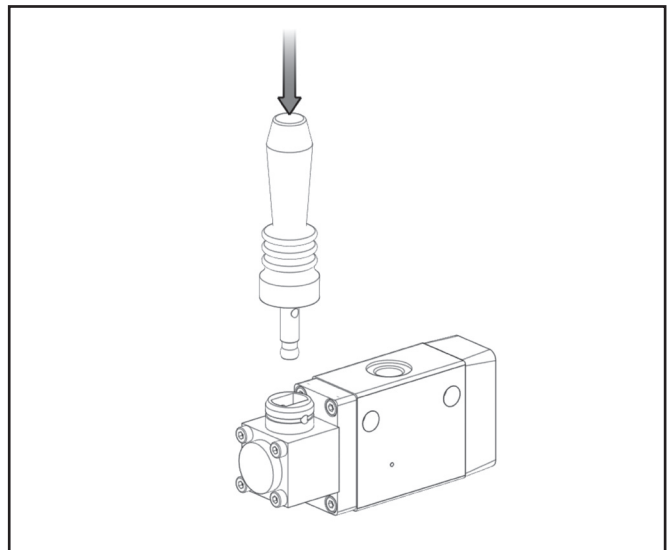

10. Now just lift the bellow little up and insert the pin which passes through both bracket and knob.

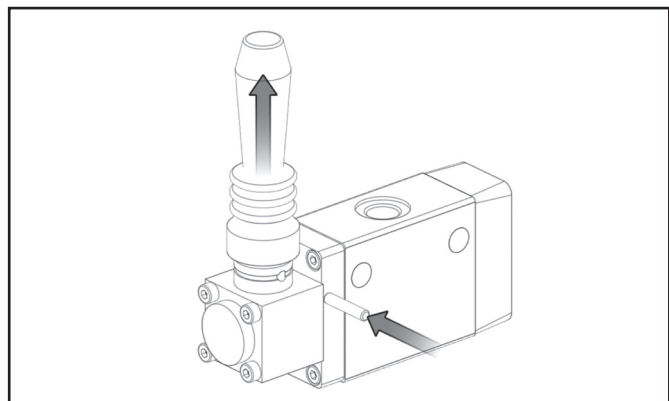

7.1 Part list

Sr. No.	Name	Quantity
1	BODY	1
2	SPOOL	1
3	SPRING COVER	1
4	SPRING	2
5	HAND OP MTG COVER	1
6	HANDLE MTG BRACKET	1
7	GUIDE BOSS WITH KNOB	1
8	BELLOW	1
9	PIN	1
10	BUSH	1
11	BALL HOLDER	1
12	SEAL FOR SPOOL	4
13	ORING 2.57 x 1.78	2
15	DIN 912 M4 x 12 -12	8
16	DIN 444 M8 x 25 EYE BOLT	1
17	DIN 912 M4 x 35 - 20	4
18	BALL DIA 2 IS 2898	2
19	BALL DIA 6 IS 2898	2
20	FILTER	1
21	DUST CAP FOR 1/4"	3

8. PACKAGING & STORE

1. When not in use, DAQ204 ASSEMBLY should be kept in a sealed plastic bag in a cardboard box to prevent moisture or dust from contacting product.
2. DAQ204 should be stored in a dry place free from water and dust.
3. Store at temperature between 40°F and 120°F (4°C and 49°C).
4. Locate in an area to avoid damage by impact.

9. ASSISTANCE

For technical questions or assistance, contact any authorized distributor of Neles India Private limited or:

Subject to change without prior notice.
Product names in this bulletin are all trademarks of Neles Finland Inc.

Metso Corporation

Töölönlahdenkatu 2, P.O. Box 1220, 00100 Helsinki, Finland
Tel. +358 20 484 100

Neles Finland Inc.

Vanha Porvoontie 229, P.O. Box 304, FI-01301 Vantaa, Finland
Tel. +358 20 483 150

Neles USA Inc.

44 Bowditch Drive, P.O. Box 8044, Shrewsbury, MA 01545, USA.
Tel. +1 508 852 0200

<http://contact.metso.com/>

www.metso.com/valves

